



ООО Научно-производственное предприятие

**СИГМА-С**

443052, г. Самара, ул. Земеца, 4, корпус 94"Б" Т/ф: (846) 931-99-28, 931-99-24(сбыт)  
E-mail: sigma-s@smrk.ru www.npp-sigma-s.ru

### C-LEVER® II -

: \_\_\_\_\_

: \_\_\_\_\_

:	<input type="checkbox"/>	<input type="checkbox"/>	<input type="checkbox"/>
	<input type="checkbox"/>	<input type="checkbox"/>	<input type="checkbox"/>
	<input type="checkbox"/>	<input type="checkbox"/>	<input type="checkbox"/>

[°C] \_\_\_\_\_

∴ \_\_\_\_\_ [ / ] ∴ \_\_\_\_\_ [ / ]

**C-LEVER® II mini**  
( 50 / 2 3/ )

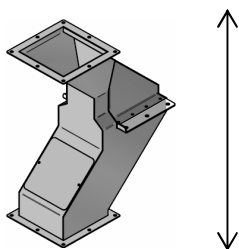

**C-LEVER® II**  
( 600 / 75 3/ ; )

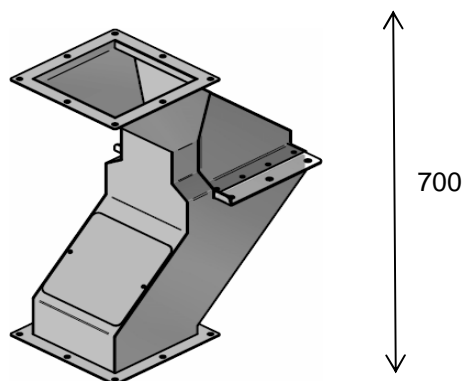

, ∴ \_\_\_\_\_

: \_\_\_\_\_

- : \_\_\_\_\_

: \_\_\_\_\_

. ,, , E-mail: \_\_\_\_\_

, : \_\_\_\_\_

( ,, ,, ,, , E-mail) \_\_\_\_\_